

Rock Island Dam Downstream Parapet Wall Replacement

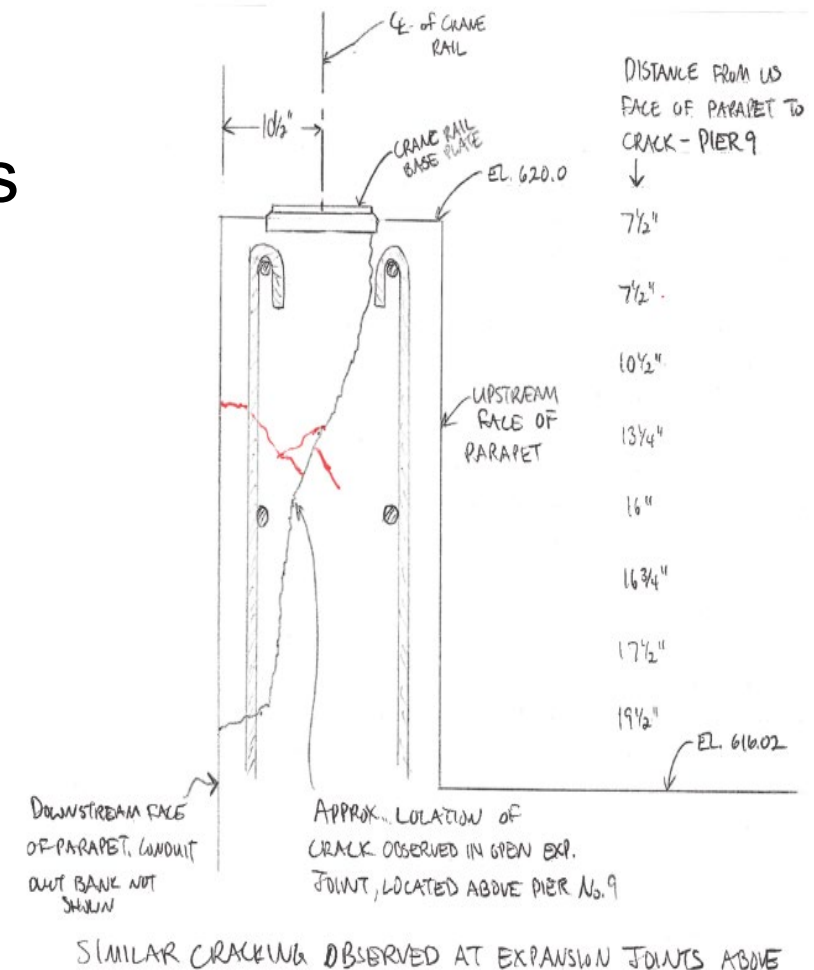

Why We Are Here

- June 2024 Emergency Declaration for purposes of expediting Procurement
- Gantry Crane and Spillway Capacity Reduced Function
- Downstream Parapet Wall Requires Replacement
- Motion to approve Downstream Parapet Wall Capital Project and Budget



Downstream Parapet Wall Replacement

- Remove 1,150 ft of 4 ft tall x 2 ft wide wall
- Build 4 to 5 sets of catwalk to stage the work
- Temporarily support conduits
- Place 32 beams each weighing 20 tons
- Commission Gantry Cranes

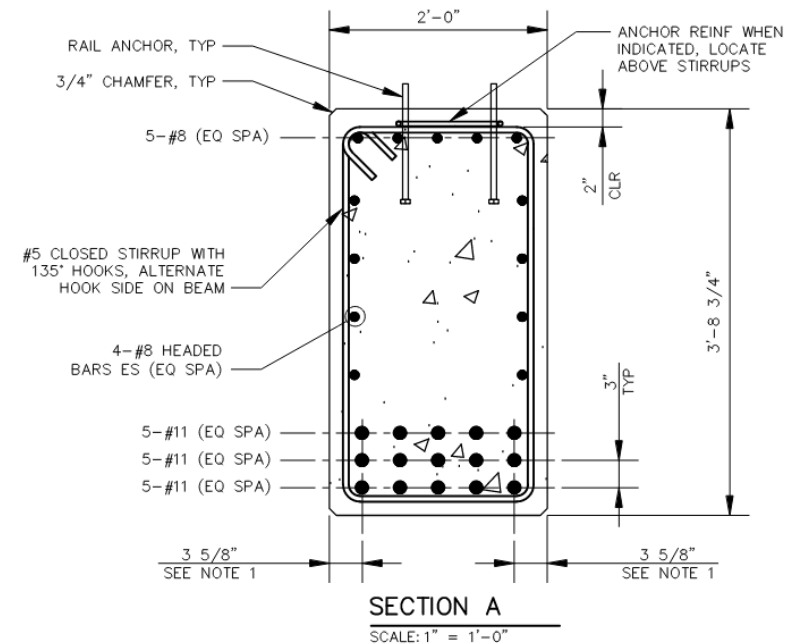
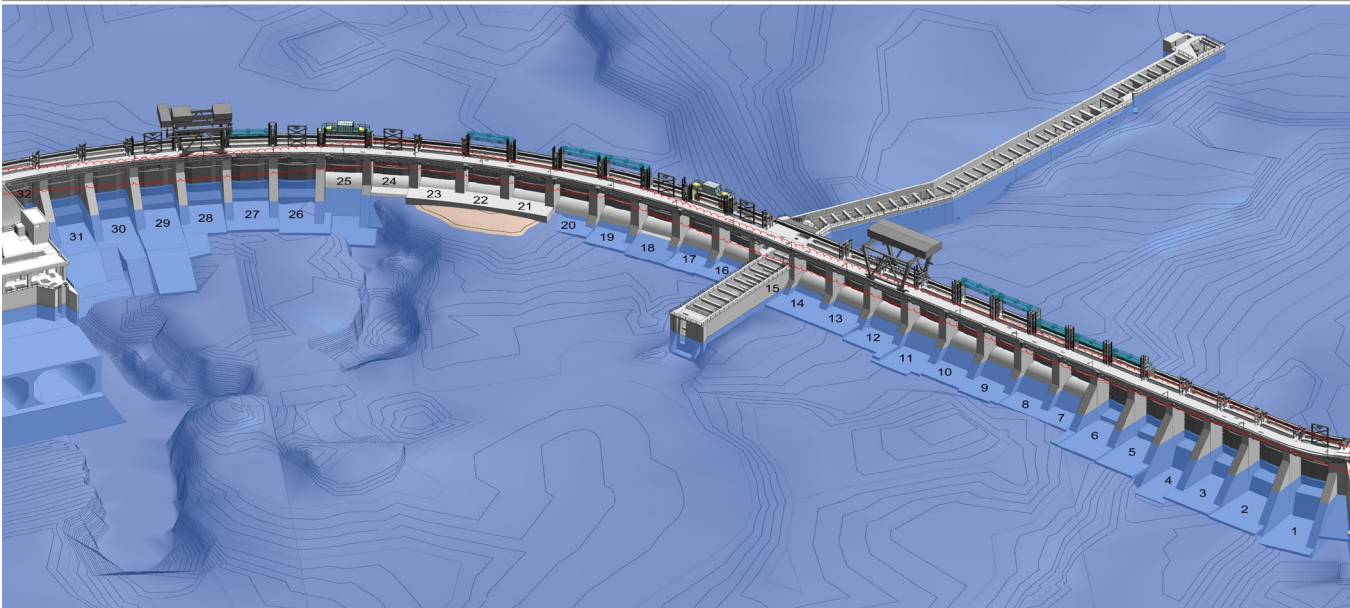
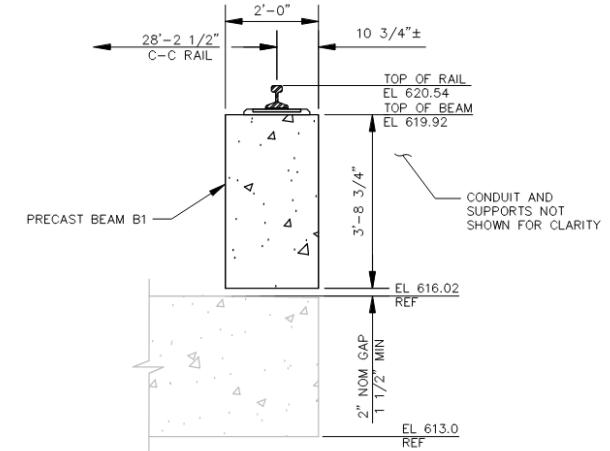

Downstream Parapet Wall Budget Request and Forecast

- 2024-25 Capital Budget Request \$34,000,000
- Future forecast spending \$26,000,000
- Includes 20% contingency amounting to \$10,400,000
- Total cost \$60,000,000

Proposed Motion

To establish a new capital project and associated budget for the Rock Island Downstream Parapet Wall Replacement in the amount of \$34,000,000.